

Released 2010
Achievement
Test

Mathematics

GRADE
6



Government
of Alberta ■

Alberta ■

Freedom To Create. Spirit To Achieve.

This document contains a release of selected test items from the 2010 Mathematics Achievement Test in Grade 6.

A test blueprint and an answer key are included in this document. These materials, along with the [program of studies](#) and [subject bulletin](#), provide information that can be used to inform instructional practice.

[Assessment Highlights](#) reports for all achievement test subjects and grades will be posted on the [Alberta Education](#) website every year in the fall. *Assessment Highlights* provide information about the overall test, the test blueprints, and student performance on the 2010 Mathematics Achievement Test in Grade 6. Also provided is commentary on student performance at the acceptable standard and the standard of excellence on selected items from the 2010 Achievement test. This information is intended for teachers and is best used in conjunction with the multi-year and detailed school reports that are available to schools via the extranet.

For further information, contact

Kelly Rota, Grade 6 and 9 Mathematics Assessment Standards Team Leader, at Kelly.Rota@gov.ab.ca;

Delcy Rolheiser, Grade 6 and 9 Mathematics Examiner, at Delcy.Rolheiser@gov.ab.ca; or

Ken Marcellus, Director, Achievement Testing, at Ken.Marcellus@gov.ab.ca, in the Assessment Sector, or call (780) 427-0010. To call toll-free from outside Edmonton, dial 310-0000.

The [Alberta Education](#) website: education.alberta.ca.

Copyright 2011, the Crown in Right of Alberta, as represented by the Minister of Education, Alberta Education, Assessment Sector, 44 Capital Boulevard, 10044 108 Street NW, Edmonton, Alberta T5J 5E6, and its licensors. All rights reserved.

Special permission is granted to **Alberta educators only** to reproduce, for educational purposes and on a non-profit basis, parts of this document that do **not** contain excerpted material.

Excerpted material in this document **shall not** be reproduced without the written permission of the original publisher (see credits, where applicable).

Contents

2010 Grade 6 PILOT Mathematics Achievement Test Blueprint (2007 Program of Studies).....	1
Additional Information.....	2
Grade 6 Mathematics Pilot Achievement Test.....	5

2010 Grade 6 PILOT Mathematics Achievement Test Blueprint (2007 Program of Studies)

Program of Study Strands	Reporting Category: Item Complexity			Number (Percentage) of items
	Low Complexity Items	Moderate Complexity Items	High Complexity Items	
Number	2, 4, 18, 36, 38	1, 9, 25, 28, 30, 33, 37, NR4	14, 17, 27, NR2	17 (34%)
Patterns and Relations	8, 19, NR1, NR7	5, 12, 13, 26, 34, NR6	29, NR5	12 (24%)
Shape and Space	3, 11, 16, 20, 23, 31, 35, NR10	6, 7, 22, 24, 32, 39, NR8, NR9		16 (32%)
Statistics and Probability	21	15, 40, NR3	10	5 (10%)
Number (Percentage) of Questions	18 (36%)	25 (50%)	7 (14%)	50 (100%)

Additional Information

The table below provides additional information about 47 of the 50 items that appeared on the 2010 Grade 6 Pilot Mathematics Achievement Test.

Item	Key	Correct Response %	Item Complexity	Strand	Specific Outcome	Item Description
MC 1	C	0.420	M	N	5	Identify the part-to-whole ratio that represents a real-life context.
MC 2	D	0.757	L	N	6	Express a given fraction that represents a real-life context as a percentage.
MC 3	B	0.850	L	SS	4	Identify a specified triangle from a given set of triangles.
MC 5	B	0.851	M	PR	3	Use a pattern rule to extend a given pattern.
MC 7	C	0.497	M	SS	3	Given a small and large right rectangular prism, determine the number of small prisms that can fit into the large prism.
MC 8	C	0.773	L	PR	1	Determine the relationship shown on a graph to make a prediction.
MC 9	B	0.840	M	N	7	Determine the statement that describes the relationship between three integers.
MC 10	C	0.168	H	SP	1	Read and interpret a multiple-line graph to draw a conclusion.
MC 11	B	0.725	L	SS	8	Match points in the first quadrant of the Cartesian plane with their corresponding order pair.
MC 12	D	0.859	M	PR	2	Determine the statement that represents the relationship in a given table of values.
MC 13	B	0.827	M	PR	5	Given a pictorial representation of a balanced scale, determine the mass of an object that is represented by a letter variable.
MC 14	D	0.254	H	N	5	Determine the ratio that represents a context involving a small and large gear.
MC 15	B	0.742	M	SP	2	Determine the survey sample that is most representative of a given population.
MC 17	C	0.751	H	N	7	Determine the integer value that satisfies given conditions (e.g. less than or greater than a certain integer value, etc.).
MC 18	A	0.752	L	N	6	Determine the ratio that represents the solution to a problem involving percent.
MC 19	C	0.527	L	PR	5	Given an equation, identify the operations that would preserve equality.

Item	Key	Correct Response %	Item Complexity	Strand	Specific Outcome	Item Description
MC 20	A	0.697	L	SS	8	Match a set of coordinates to the vertices of a 2-D shape displayed in the first quadrant of the Cartesian plane.
MC 21	A	0.757	L	SP	4	Determine the theoretical probability of an experiment involving coin tossing.
MC 22	B	0.424	M	SS	3	Given four different 2-D shapes displayed on a geoboard, determine the shape that represents a certain percentage of the geoboard's total area.
MC 23	C	0.831	L	SS	3	Compare four different right rectangular prisms to determine the prism that has the greatest volume.
MC 24	A	0.633	M	SS	3	Generalize a rule (formula) for determining the perimeter and area of a given rectangle.
MC 25	D	0.738	M	N	9	Identify and apply the order of operations to solve a given problem involving money.
MC 26	D	0.625	M	PR	2	Determine the relationship between two variables as represented in a table of values, and identify the equation that represents the relationship.
MC 27	A	0.632	H	N	4	Determine the mixed number that represents a certain quantity that is greater than 1.
MC 28	D	0.701	M	N	9	Determine the equation that represents the application of the correct order of operations to solve a given problem.
MC 29	C	0.595	H	PR	2	Predict the value of an unknown term using the relationship in a given table of values.
MC 30	C	0.349	M	N	9	Apply the order of operations to solve a multistep problem involving whole numbers and decimal numbers.
MC 31	D	0.662	L	SS	6	Reflect given 2-D shapes across a line of reflection to determine which shapes are congruent to their images.
MC 32	B	0.391	M	SS	4	Plot two ordered pairs in the first quadrant of the Cartesian plane and use one of four plotted points to create an isosceles triangle.
MC 33	A	0.707	M	N	7	Apply understanding of integers to represent the position of an object after the object has undergone a series vertical up and down movements.
MC 34	B	0.724	M	PR	4	Identify the unknown in a problem; represent the problem with an equation; and solve the problem concretely, pictorially, or symbolically.

Item	Key	Correct Response %	Item Complexity	Strand	Specific Outcome	Item Description
MC 35	B	0.765	L	SS	8	Match a plotted point in the first quadrant of the Cartesian plane with its corresponding ordered pair.
MC 36	C	0.564	L	N	6	Express a given percent as a fraction and a decimal.
MC 37	A	0.852	M	N	4	Represent a given context as an improper fraction, and express the improper fraction as a mixed number.
MC 38	D	0.772	L	N	1	Apply understanding of place value to match the symbolic representation of a number to its equivalent representation in word form.
MC 39	A	0.639	M	SS	8	Generalize a rule (formula) for determining the volume of given right rectangular prisms.
MC 40	C	0.566	M	SP	4	Determine the theoretical probability of an outcome occurring for a probability experiment involving random selection.
NR 1	55	0.817	L	PR	4	Solve for the unknown in a given equation.
NR 2	48	0.405	H	N	6	Use a diagram composed of regular and irregular 2-D shapes to determine the percentage of the diagram that is occupied by one of the 2-D shapes.
NR 3	3	0.772	M	SP	1	Read and interpret a multiple line graph to draw a conclusion.
NR 4	72	0.653	M	N	9	Apply the order of operations to solve a multistep problem involving whole numbers and decimal numbers.
NR 5	0.85	0.293	H	PR	4	Represent a given context involving whole numbers and decimal numbers with an equation containing one unknown, and solve for the unknown.
NR 6	40	0.414	M	PR	4	Represent a given context involving whole numbers and fractions with an equation containing one unknown, and solve for the unknown.
NR 7	9	0.739	L	PR	4	Solve for an unknown in an equation and substitute the value of the unknown into a third equation to find the product of the equation.
NR 8	2	0.621	M	SS	3	Compare the side lengths of an irregular polygon to the side lengths of a given set of irregular polygons to solve a problem.
NR 9	10	0.533	M	SS	3	Determine the unknown height of a right rectangular prism when the length, width, and volume are known.
NR 10	60	0.699	L	SS	2	Determine the measure of an unknown angle in a quadrilateral when the other angles are known.

Grade 6 Mathematics Pilot Achievement Test

2010

Use the following information to answer question 1.

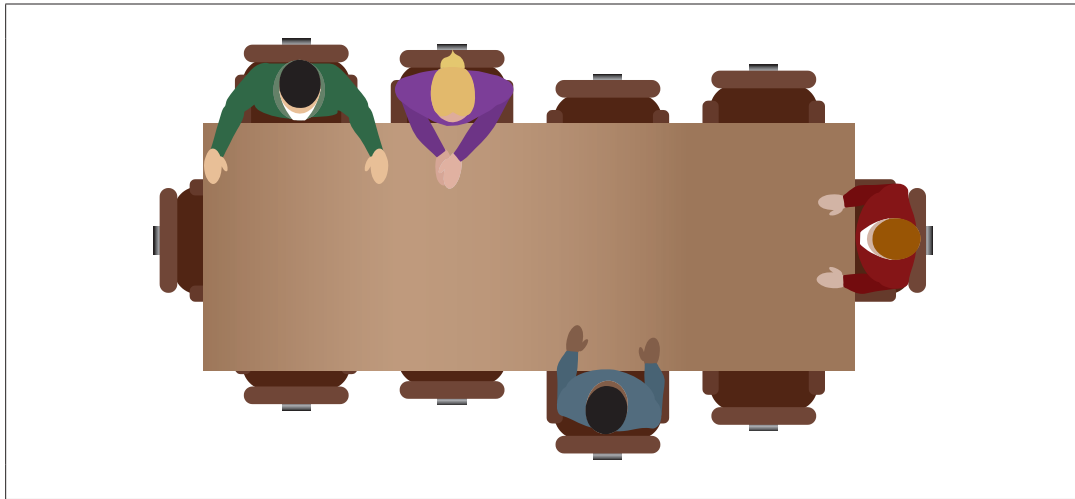

1. What is the ratio of chairs to people?

- A. 2:5
 - B. 4:5
 - C. 5:2
 - D. 5:4
-

Use the following information to answer question 2.

A chocolate bar has 10 equal sections.



2. What percentage is equivalent to $\frac{4}{5}$ of the chocolate bar?

- A. 4%
- B. 8%
- C. 40%
- D. 80%

3. Which of the following triangles is an obtuse triangle?

A.

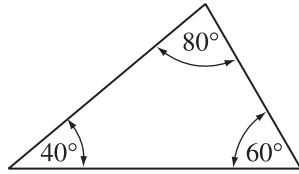

B.

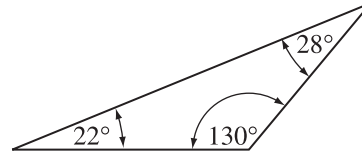

C.

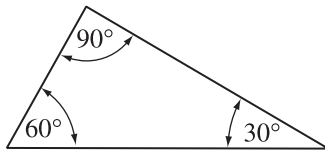

D.

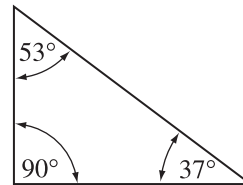

Use the following information to answer numerical-response question 1.

$$2 \times n + 3 = 113$$

Numerical Response

1. The value of n in the equation above is _____.

(Record your answer in the numerical-response section on the answer sheet.)

Multiple-choice question 4 is not being released at this time.

Use the following information to answer question 5.

Bobbie uses the following rule to generate a list of numbers:

Rule: Multiply the previous number by 2 and then add 3.

5. If the first three numbers that Bobbie generates are 6, 15, and 33, then the next three numbers are
- A. 69, 140, 282
 - B. 69, 141, 285
 - C. 100, 202, 406
 - D. 100, 302, 906
-

Multiple-choice question 6 is not being released at this time.

Use the following information to answer numerical-response question 2.

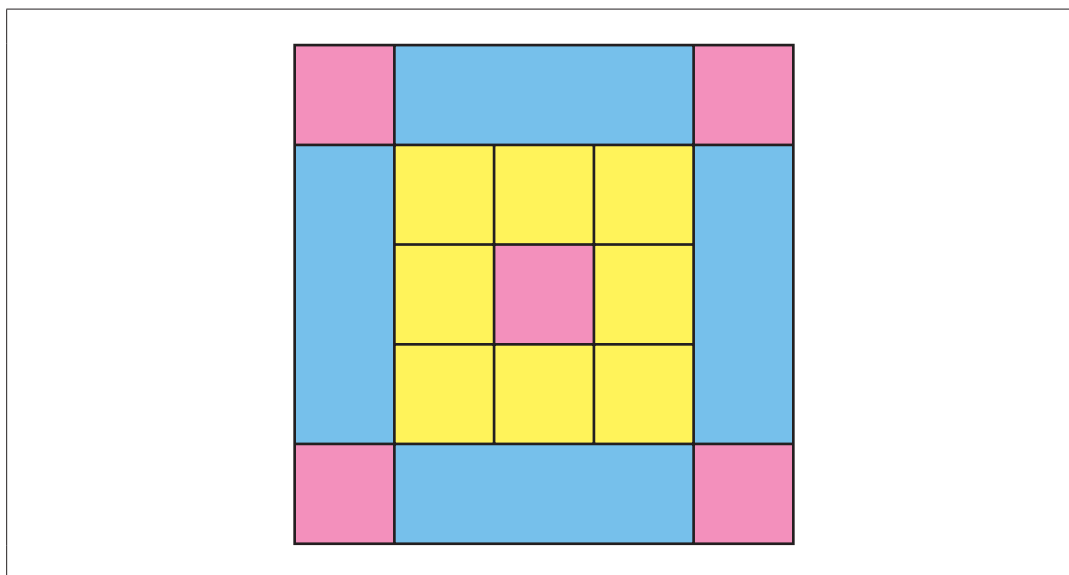

Numerical Response

2. What percentage of the diagram shown above is shaded blue?

Answer: _____ %

(Record your answer in the numerical-response section on the answer sheet.)

Use the following information to answer question 7.

The dimensions of a package of paper and a box are shown below.

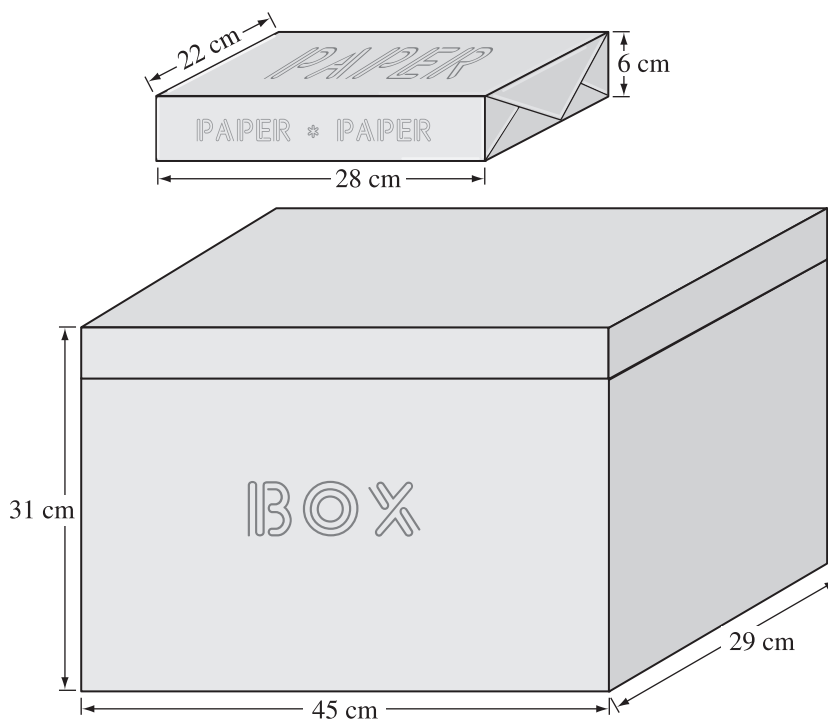

7. What is the **maximum** number of paper packages that could completely fit into the box?
- A. 8
 - B. 9
 - C. 10
 - D. 11

Use the following information to answer question 8.

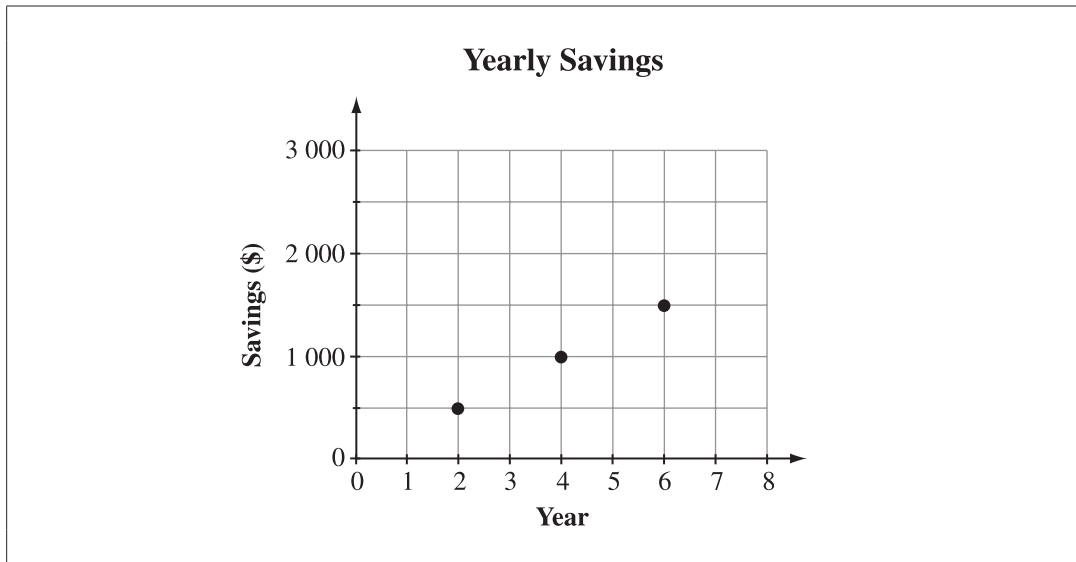

8. If the pattern in the graph continues, then how much money would be saved in year 8?

- A. \$1 500
 - B. \$1 750
 - C. \$2 000
 - D. \$2 250
-

9. Which of the following statements describes the relationship between zero and the numbers -6 and 2 ?

- A. Zero is less than negative six and less than two.
- B. Zero is greater than negative six but less than two.
- C. Zero is less than negative six but greater than two.
- D. Zero is greater than negative six and greater than two.

Use the following information to answer question 10 and numerical-response 3.

The results of a race are shown on the graph below.

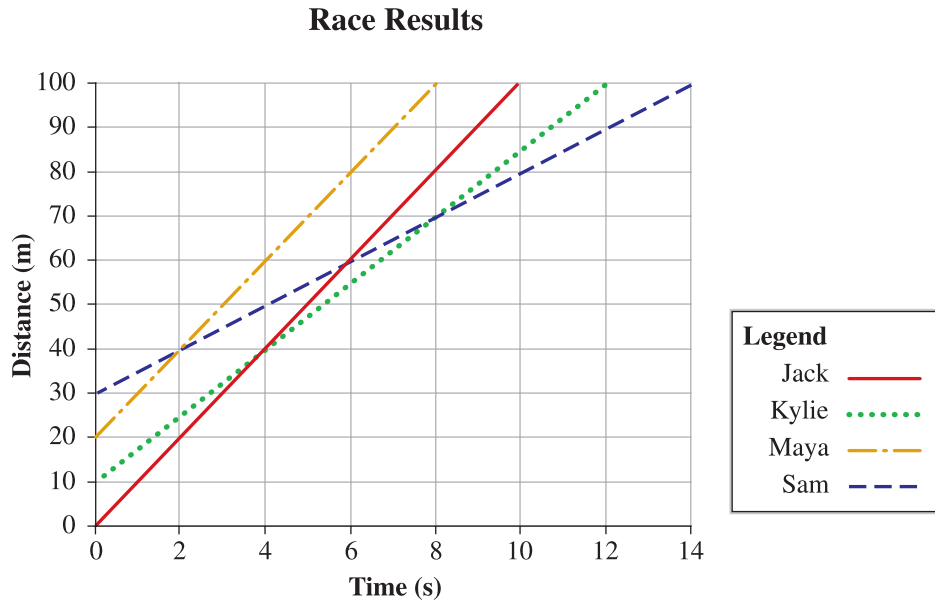

Note: Each person had a different starting point.

10. Which two people each ran 40 metres in 4 seconds?
- A. Sam and Kylie
 - B. Kylie and Jack
 - C. Jack and Maya
 - D. Maya and Sam

Numerical Response

3. How many times during the race was Sam passed by another runner?

Answer: _____ time(s)

(Record your answer in the numerical-response section on the answer sheet.)

Use the following information to answer question 11.

x	y
1	4
2	3
4	0

11. Which of the following graphs correctly displays the data in the table shown above?

A.

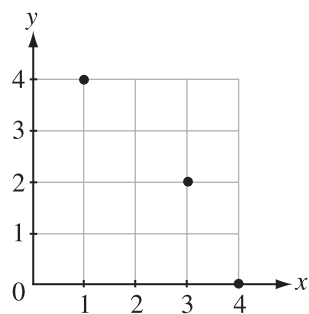

B.

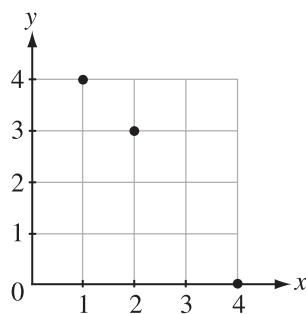

C.

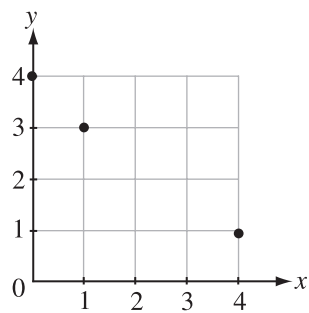

D.

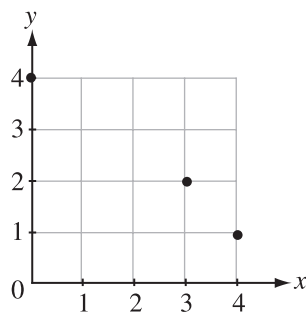

Use the following information to answer question 12.

Input	Output
1	4
2	7
3	10
4	13

12. Which of the following statements describes the relationship between the input and the output in the table above?
- A. Multiply the input by 4 to get the output.
 - B. Double the input and add 2 to get the output.
 - C. Double the input and add 4 to get the output.
 - D. Multiply the input by 3 and add 1 to get the output.
-

Use the following information to answer question 13.

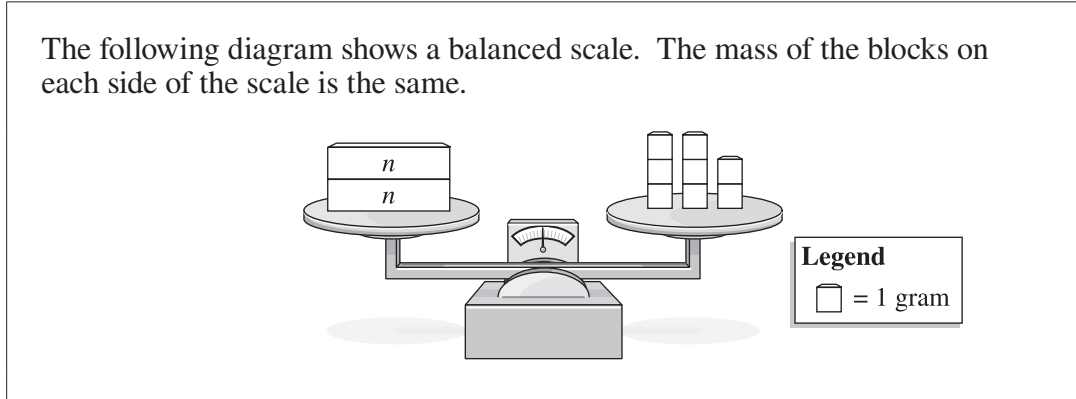

13. The mass of 1 block labelled by the letter n is
- A. 2 grams
 - B. 4 grams
 - C. 6 grams
 - D. 8 grams

Use the following information to answer question 14.

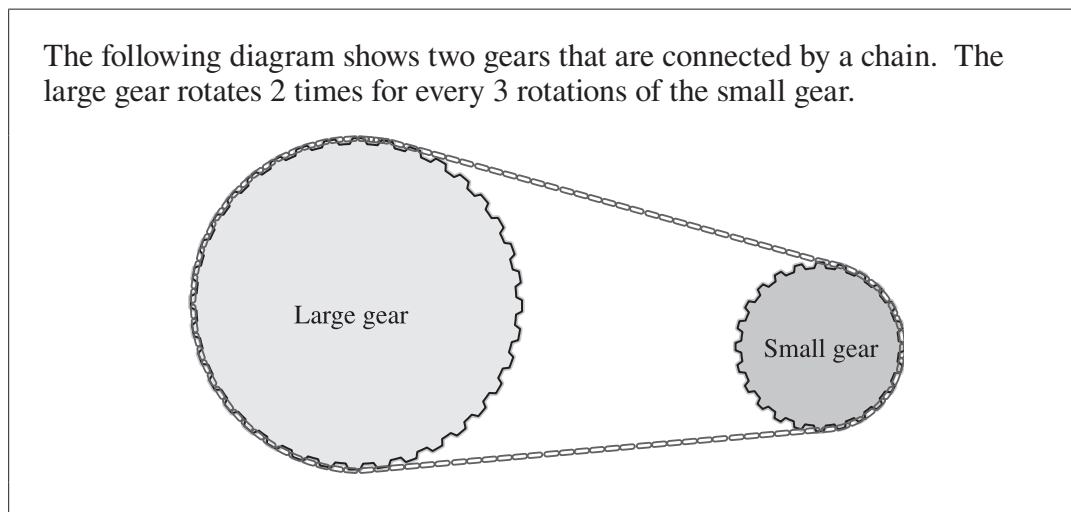

14. What is the total number of rotations of **both** gears when the large gear rotates 36 times?
- A. 54 rotations
 - B. 60 rotations
 - C. 72 rotations
 - D. 90 rotations
-

Use the following information to answer question 15.

Hannah wants to know if Grade 6 students in her school prefer skiing to snowboarding.

15. Which of the following groups of students should Hannah survey?
- A. Students on the Grade 6 ski team
 - B. All Grade 6 students in her school
 - C. Students on the Grade 6 snowboard team
 - D. Grade 6 students from the school's ski and snowboard club

Multiple-choice question 16 is not being released at this time.

Use the following information to answer numerical-response question 4.

A monthly bus pass costs \$40.00, and a yearly bus pass costs \$408.00.

Numerical Response

- 4.** How many dollars would a person save by purchasing a yearly bus pass rather than 12 monthly passes?

Answer: _____ **dollars**

(Record your answer in the numerical-response section on the answer sheet.)

Use the following information to answer question 17.

Ben is thinking about a certain integer that is:

- less than -5
- greater than -12
- closer to -12 than to -5

17. Which of the following integers could Ben be thinking about?

- A. -4
 - B. -6
 - C. -10
 - D. -14
-

Use the following information to answer question 18.

A bag contains 300 marbles of which 24% are green.

18. Which of the following equations can be used to find the total number, n , of green marbles?

- A. $\frac{24}{100} = \frac{n}{300}$
- B. $\frac{300}{n} = \frac{24}{100}$
- C. $\frac{24}{100} = \frac{200}{n}$
- D. $\frac{100}{200} = \frac{n}{24}$

Use the following information to answer question 19.

Left Side	Right Side
$12 + 6 = 22 - 4$	

19. Which of the following operations would preserve equality in the equation shown above?
- A. Subtract 4 from the left side and add 4 to the right side
 - B. Subtract 6 from the left side and add 4 to the right side
 - C. Subtract 6 from the left side and subtract 6 from the right side
 - D. Subtract 4 from the left side and subtract 6 from the right side

Use the following information to answer numerical-response question 5.

John spends \$3.65 on 1 bottle of juice, 2 muffins, 1 package of gum, and 3 sour treats at a convenience store. The chart below shows the cost of each item.

Item	Cost
Bottle of juice	\$1.25
Muffin	?
Package of gum	\$0.55
Sour treat	\$0.05

Numerical Response

5. What is the cost of 1 muffin?

Answer: \$ _____

(Record your answer in the numerical-response section on the answer sheet.)

Use the following information to answer question 20.

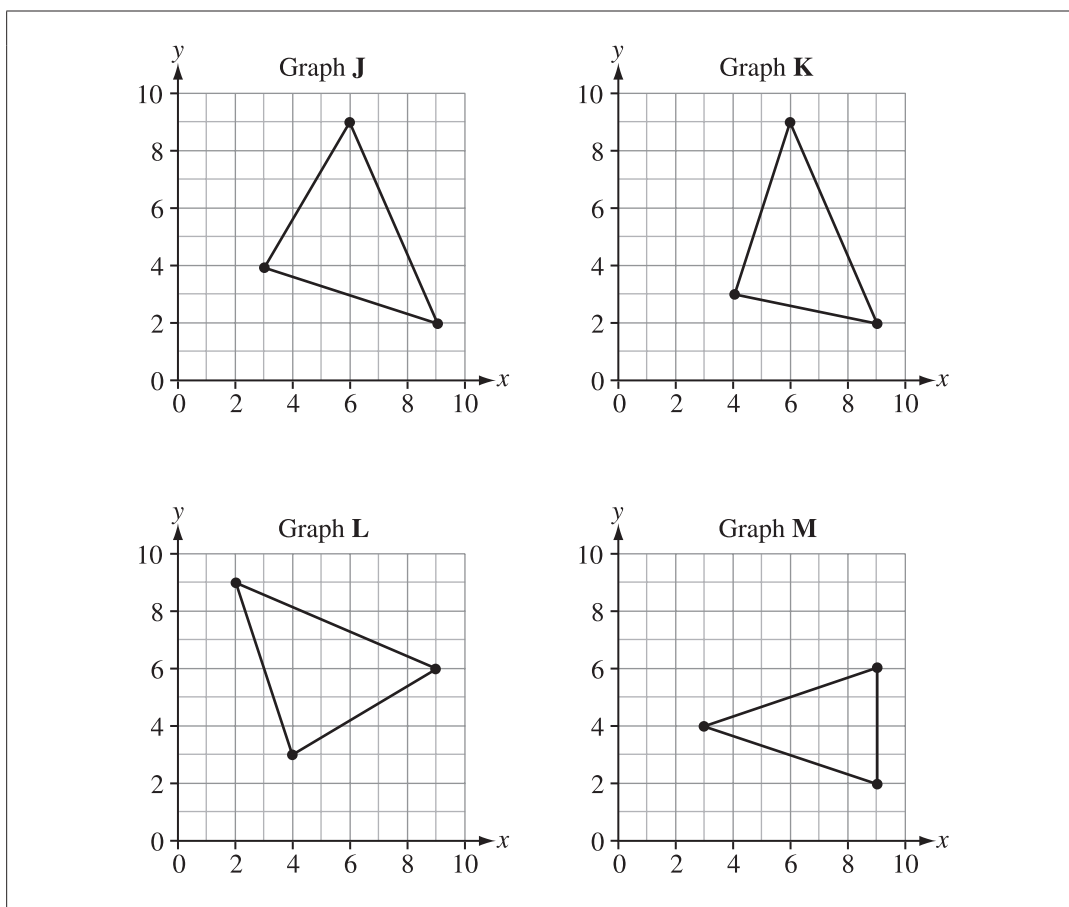

20. Which graph shown above has a triangle with the coordinates (3, 4), (9, 2), and (6, 9) at its vertices?
- A. Graph J
 - B. Graph K
 - C. Graph L
 - D. Graph M

Use the following information to answer question 21.

Kerry randomly flips a coin 10 times. She records the number of times the coin lands on heads or tails in one of the tally charts shown below.

Tally chart 1		Tally chart 2		Tally chart 3		Tally chart 4	
Heads	Tails	Heads	Tails	Heads	Tails	Heads	Tails

21. Which tally chart represents the theoretical probability of Kerry's results?
- A. Tally chart 1
 - B. Tally chart 2
 - C. Tally chart 3
 - D. Tally chart 4

Use the following information to answer numerical-response question 6.

Kate saves $\frac{1}{2}$ of the \$10.00 she receives each week from her parents. She is going to use her savings to buy a camera that costs a total of \$196.00 (including the Goods and Services Tax).

Numerical Response

6. How many weeks will it take Kate to save enough money to buy the camera?

Answer: _____ **weeks**

(Record your answer in the numerical-response section on the answer sheet.)

Use the following information to answer question 22.

Four shapes were created by placing elastic bands around pegs on a geoboard, as shown below.

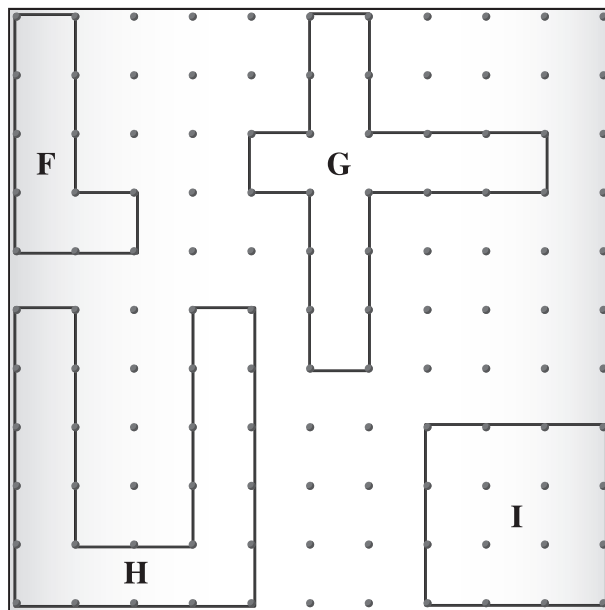

22. Which shape contains 10% of the geoboard's total area?

- A. Shape F
- B. Shape G
- C. Shape H
- D. Shape I

23. Which of the following rectangular prisms has the **greatest** volume?

A.

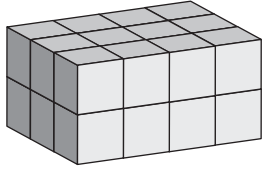

B.

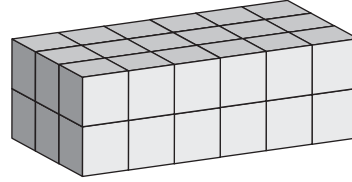

C.

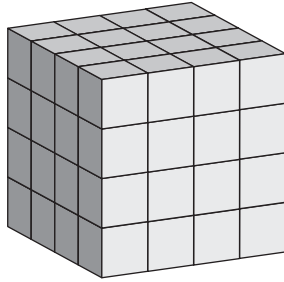

D.

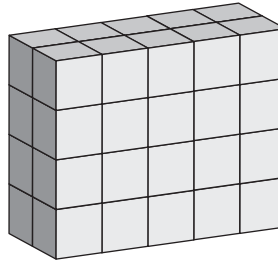

Use the following information to answer question 24.

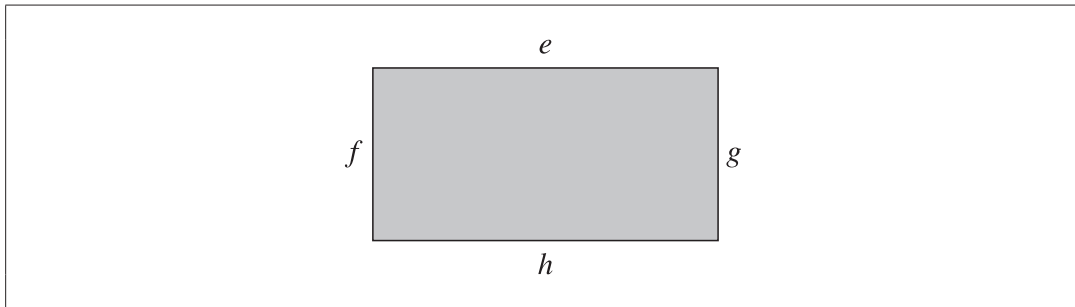



24. Which of the following rows represents a formula for finding the perimeter and area of the rectangle above?

Row	Perimeter	Area
A.	$e + f + g + h$	$g \times h$
B.	$g \times h$	$e + f + g + h$
C.	$(f + g) + (e + h)$	$(f + g) \times (e + h)$
D.	$(f + g) \times (e + h)$	$(f + g) + (e + h)$

Use the following information to answer question 25.

The menu below shows the items sold at a concession and the cost of each item.

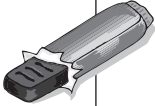
Menu		
Can of juice		\$1.25
Slice of pizza		\$2.25
Bag of peanuts		\$1.00
Chocolate bar		\$1.25

25. If a student purchased 1 can of juice, 2 slices of pizza, 1 bag of peanuts, and 2 chocolate bars using a \$20.00 bill, then her change was
- A. \$9.25
 - B. \$9.75
 - C. \$10.25
 - D. \$10.75

Use the following information to answer question 26.

A table of values is shown below.

x	1	2	3	4	5
y	3	5	7	9	11

26. Which of the following equations represents the relationship between the x and y shown in the table above?

- A. $y = x$
 - B. $y = x + 1$
 - C. $y = 2x$
 - D. $y = 2x + 1$
-

Use the following information to answer numerical-response question 7.

Equation 1 $2 \times \square = 6$

Equation 2 $3 \times \square = ?$

Equation 3 $4 \times \square = 12$

Numerical Response

7. If the value of \square is the same for all three equations, then the product in **Equation 2** is _____.

(Record your answer in the numerical-response section on the answer sheet.)

Use the following information to answer question 27.

Shannon makes 6 grilled-cheese sandwiches for her 4 children. Her oldest child eats 3 sandwiches, and her youngest child eats only $\frac{1}{4}$ of a sandwich.

27. How many sandwiches do Shannon's other 2 children eat if all the sandwiches are eaten?
- A. $2\frac{3}{4}$
 - B. $2\frac{1}{4}$
 - C. $1\frac{3}{4}$
 - D. $1\frac{1}{4}$
-

Use the following information to answer question 28.

A restaurant charges \$60 per hour and \$10 per person for parties.

28. Which of the following equations can be used to determine the total cost for a 3-hour party for 35 people?
- A. Total cost = $(60 \times 35) \times (10 \times 3)$
 - B. Total cost = $(60 \times 35) + (10 \times 3)$
 - C. Total cost = $(60 \times 3) \times (10 \times 35)$
 - D. Total cost = $(60 \times 3) + (10 \times 35)$

Use the following information to answer question 29.

Each day Jessie deposits money into her piggy bank according to the pattern shown in the chart below.

Day	Amount Deposited
1	\$1.00
2	\$2.00
3	\$3.00
4	\$4.00

29. Jessie continues to deposit money into her piggy bank according to the pattern shown in the chart above. How many days does it take her to deposit a **total** of \$21.00?
- A. 4 days
 - B. 5 days
 - C. 6 days
 - D. 7 days
-

Use the following information to answer question 30.

Louise charges \$5 per hour for babysitting one child and \$1.25 per hour for each additional child.

30. How much would Louise charge to babysit 4 children for 6 hours?
- A. \$30.00
 - B. \$37.50
 - C. \$52.50
 - D. \$60.00

Use the following information to answer question 31.

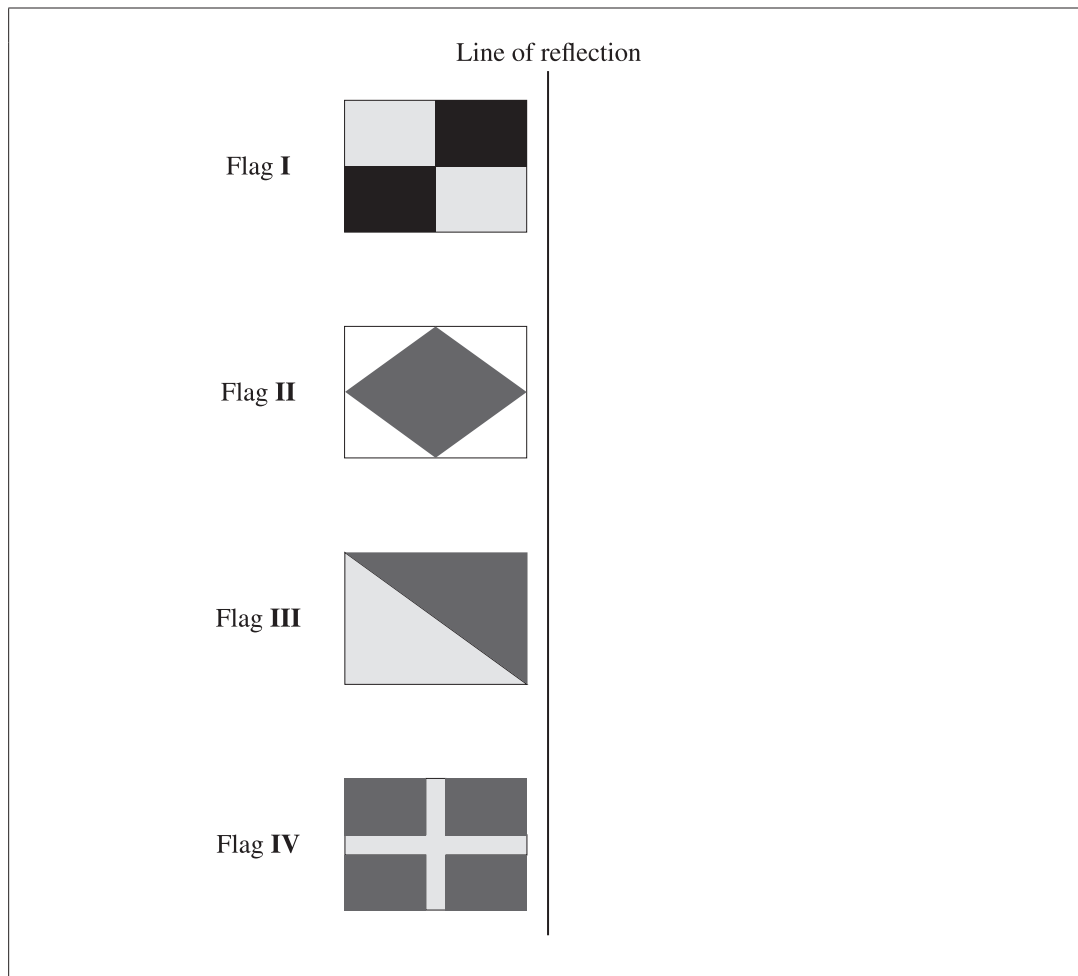

31. Which two flags create identical images when reflected across the line of reflection shown above?
- A. Flag I and Flag III
 - B. Flag I and Flag IV
 - C. Flag II and Flag III
 - D. Flag II and Flag IV

Use the following graph to answer question 32.

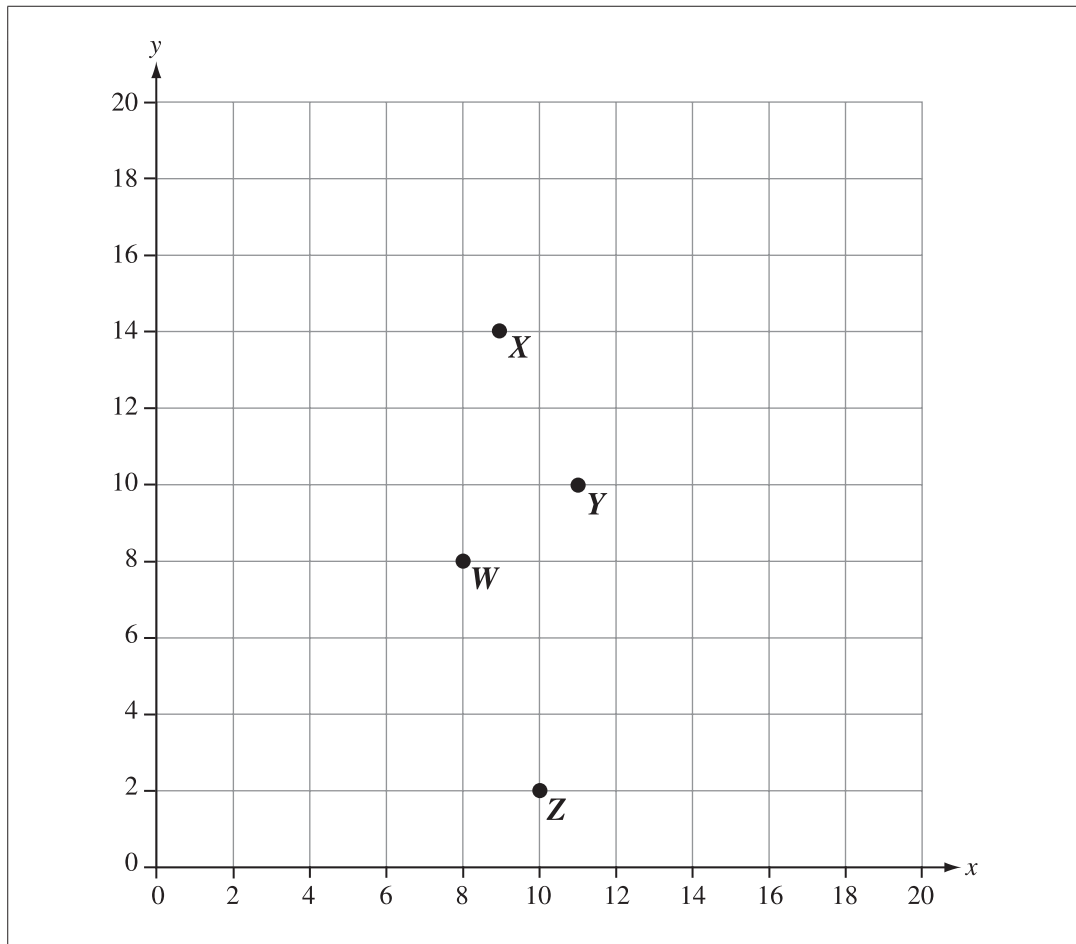

32. If the coordinates $(5, 4)$ and $(13, 4)$ are plotted on the graph above, then which of the points labelled on the graph could be used as a third point to create an isosceles triangle?
- A. W
 - B. X
 - C. Y
 - D. Z

Use the following information to answer numerical-response question 8.

A thank-you card and four envelopes are shown below.

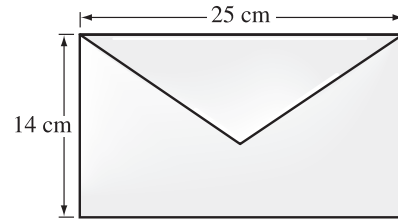
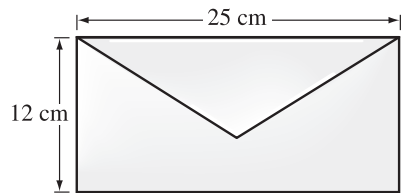
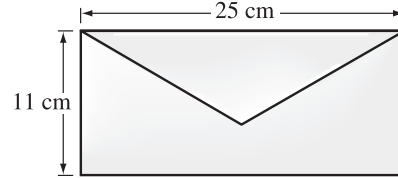
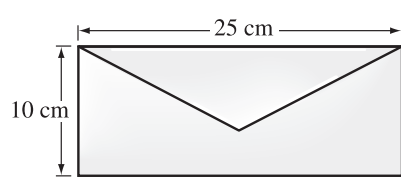
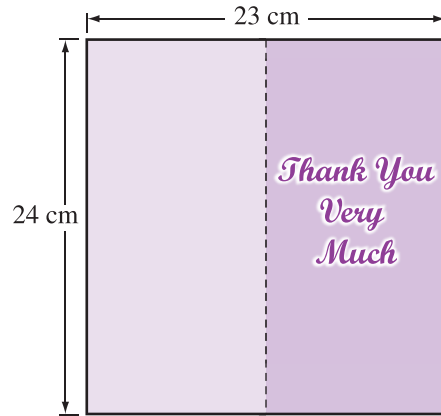

Note: The diagrams shown above are not drawn to scale.

Numerical Response

8. How many of the envelopes are large enough to contain the thank-you card if the card is folded in half along the dotted line shown above?

Answer: _____ envelope(s)

(Record your answer in the numerical-response section on the answer sheet.)

Use the following information to answer question 33.

Margo uses integers to represent floor levels in a building. Starting at ground level (floor 0), an elevator travels in the following directions:

- down 5 floors
- up 1 floor
- up 7 floors
- down 8 floors

33. If floors that are below ground level are represented by negative integers, then on which floor does the elevator make its **last** stop?
- A. -5
B. -4
C. -3
D. -2
-

Use the following information to answer question 34.

Josh has 30 hockey cards. He keeps 10 cards for himself and gives 5 cards to his sister. Josh then shares the remaining cards equally among 5 friends.

34. How many cards does Josh give to each friend?
- A. 2
B. 3
C. 4
D. 5

Use the following information to answer question 35.

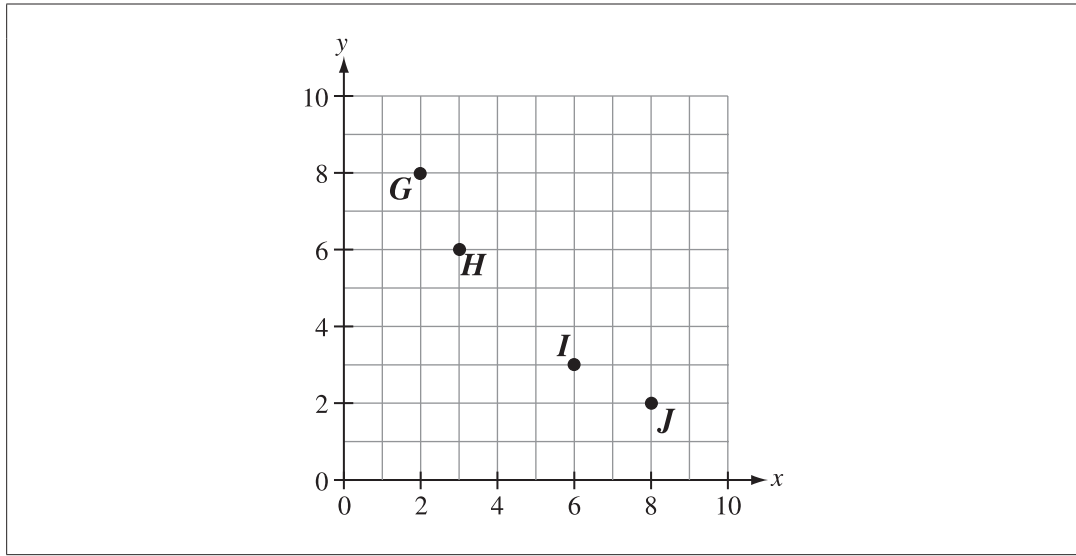

35. In the graph above, which letters are located at the coordinate positions (2, 8) and (6, 3)?

- A. *G* and *H*
 - B. *G* and *I*
 - C. *H* and *J*
 - D. *I* and *J*
-

36. Which row shows the fraction form and the decimal form of 7%?

Row	Fraction Form	Decimal Form
A.	$\frac{7}{10}$	0.07
B.	$\frac{7}{10}$	0.7
C.	$\frac{7}{100}$	0.07
D.	$\frac{7}{100}$	0.7

Use the following information to answer question 37.

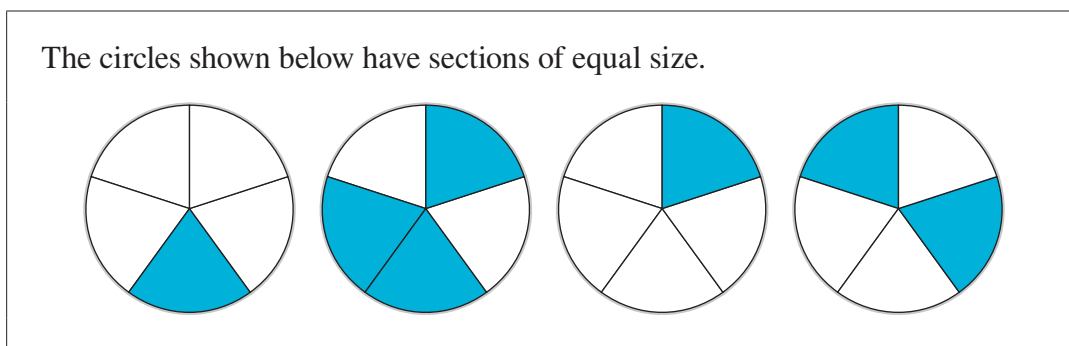

37. How many new circles can be made using only the blue sections?

- A. $1\frac{2}{5}$
 - B. $1\frac{5}{2}$
 - C. $1\frac{5}{7}$
 - D. $1\frac{7}{5}$
-

38. The number 1 100 010 101.001 can be written as

- A. one million ten thousand one hundred one and one thousandth
- B. one million one hundred thousand one hundred one and one hundredth
- C. one billion ten million one thousand one hundred one and one hundredth
- D. one billion one hundred million ten thousand one hundred one and one thousandth

Use the following information to answer numerical-response question 9.

The container of orange juice shown below has a volume of 200 cm^3 .

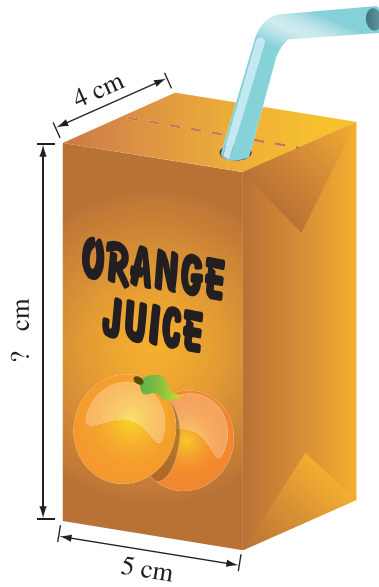

Numerical Response

9. The container of orange juice has a height of _____ cm.

(Record your answer in the numerical-response section on the answer sheet.)

Use the following information to answer question 39.

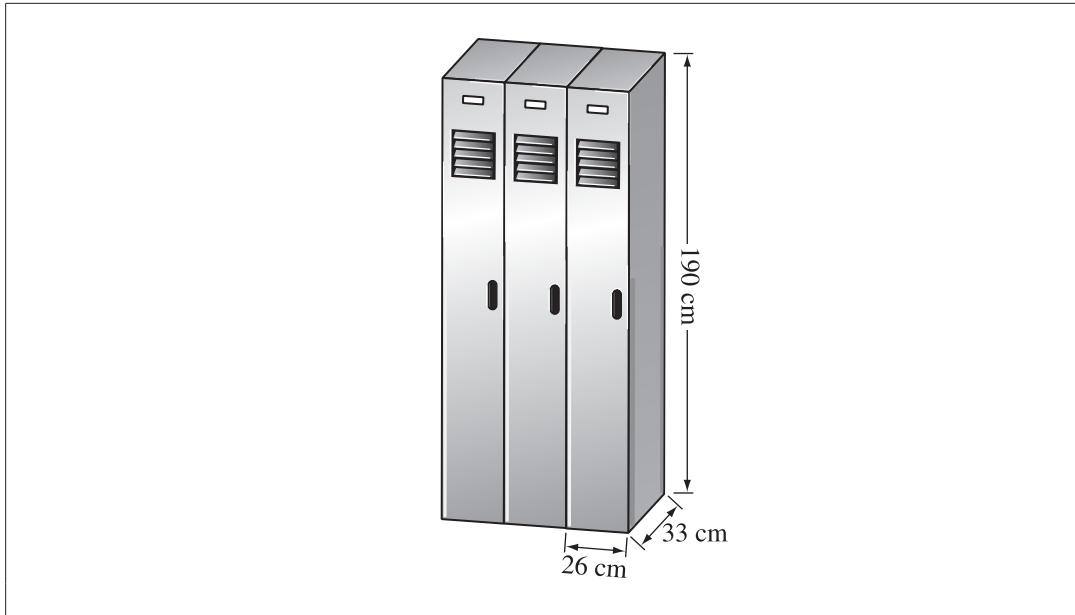

39. Which of the following expressions can be used to find the total volume of the 3 lockers?
- A. $(26 \text{ cm} \times 33 \text{ cm} \times 190 \text{ cm}) \times 3$
 - B. $(26 \text{ cm} + 33 \text{ cm} + 190 \text{ cm}) \times 3$
 - C. $(26 \text{ cm} \times 33 \text{ cm} \times 190 \text{ cm}) \div 3$
 - D. $(26 \text{ cm} + 33 \text{ cm} + 190 \text{ cm}) \div 3$

Use the following information to answer numerical-response question 10.

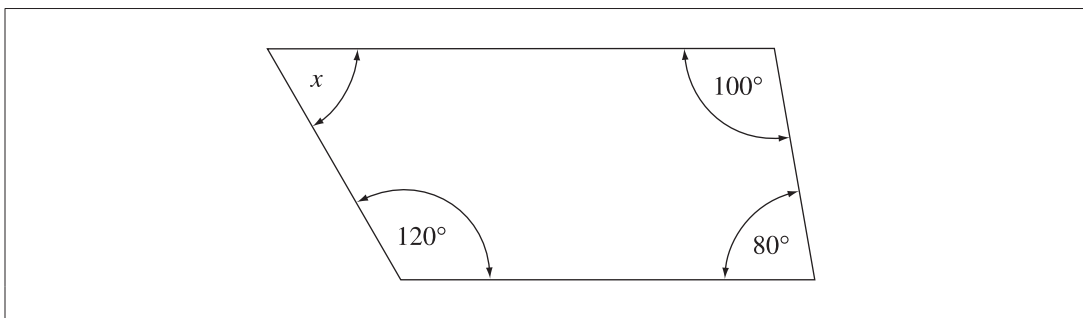

Numerical Response

10. The measure of x in the diagram above is _____ degrees.

(Record your answer in the numerical-response section on the answer sheet.)

Use the following information to answer question 40.

A teacher puts the following names in a bag to randomly select teams.

Boys' Names	Girls' Names
Ivan	Jane
Mo	Sarah
Carl	Nicole
Ken	Janet
Bob	Ashley
Sal	Stacey
Paul	
Frank	

40. The first 3 names that the teacher picks at random are Mo, Janet, and Ashley. If these 3 names are **not** put back in the bag, then what is the probability that the next name drawn will be a boy's?

- A. $\frac{8}{14}$
- B. $\frac{7}{14}$
- C. $\frac{7}{11}$
- D. $\frac{1}{6}$

